

Integration of RFID and Fingerprint Sensors in an IoT-Based Attendance System

Nirham Nurdin ^{1*}, Supriadi Sahibu ^{2*}, Abdul Jalil ^{3**}, Mashur Razak ^{4***}, Abdul Latief Arda ^{5*},
Respaty Namruddin ^{6*}

* Department of Computer Systems, Handayani University of Makassar

** Department of Computer and Informatics Engineering, Politeknik Negeri Ujung Pandang

*** Nitro Institute of Business and Finance of Makassar

nirhamnurdin72@guru.smk.belajar.id ¹, supriadi@handayani.ac.id ², abduljalil@poliupg.ac.id ³, mashur_razak@yahoo.co.id ⁴,
abdullatief@handayani.ac.id ⁵, respaty.namruddin@handayani.ac.id ⁶

Article Info

Article history:

Received 2026-02-19

Revised 2026-03-10

Accepted 2026-04-10

Keyword:

*IoT Attendance,
RFID,
Fingerprint Sensor,
Rule-Based Decision System,
Attendance Discipline.*

ABSTRACT

Student attendance discipline plays an important role in ensuring the effectiveness of the learning process in schools. However, manual attendance systems commonly used in educational institutions have several limitations, including low accuracy in recording attendance time, potential data manipulation, inefficient data collection, and the absence of real-time notifications to parents. These limitations highlight the need for a more reliable and automated attendance monitoring system. This study aims to develop and evaluate an Internet of Things (IoT)-based attendance system that integrates RFID and fingerprint authentication to improve the accuracy and transparency of student attendance monitoring. The research employed an experimental approach by comparing attendance data obtained from a conventional manual system with data generated by the proposed IoT-based attendance system. The experiment involved 25 students and was conducted over four weeks, consisting of one week of manual attendance observation followed by three weeks of IoT-based attendance implementation. The developed system was also equipped with a Rule-Based Decision System (RBDS) to automatically classify student attendance status based on real-time attendance records. The results indicate that the implementation of the IoT-based attendance system improved student attendance performance. The average attendance rate increased from 72% during the manual attendance period to 74% in the first week, 82% in the second week, and 87% in the third week after the implementation of the IoT-based system. In addition, student tardiness, which was not recorded in the manual attendance system during the period of 19–23 January 2026, became measurable after the implementation of the digital system, reaching 15% during 26–30 January 2026, then decreasing to 10% during 2–6 February 2026, and further declining to 7% during 9–13 February 2026. These results demonstrate that integrating RFID, fingerprint authentication, and IoT technology can improve the accuracy, transparency, and effectiveness of student attendance monitoring.



This is an open access article under the [CC-BY-SA](https://creativecommons.org/licenses/by-sa/4.0/) license.

I. INTRODUCTION

Student attendance is a critical indicator in assessing discipline and responsibility within the school environment while also supporting supervision and security systems. Accurate attendance recording enables schools to conduct effective evaluations and provide appropriate guidance to

students. However, the attendance system at SMK Tri Tunggal 45 Makassar remains conventional, relying on manual records or signatures. This method is prone to manipulation, facilitates attendance proxying, results in slow data recapitulation, and fails to record tardiness in detail. Furthermore, the use of non-integrated spreadsheets prevents

real-time monitoring and does not support transparency or parental supervision effectively. Similar limitations of manual attendance systems have also been reported in previous studies, which highlight inefficiency, vulnerability to fraud, and difficulties in monitoring attendance data in educational institutions [10].

The advancement of Internet of Things (IoT) technology provides a promising solution through the integration of sensors and real-time data communication, enabling automated monitoring and improved operational efficiency in educational environments [1], [9]. IoT technology has been widely adopted in smart education systems to support digital monitoring, automation, and data-driven decision making [9]. Previous research shows that RFID technology can accelerate the attendance process through card identification mechanisms that allow students to register attendance quickly and efficiently [2]. However, RFID systems remain vulnerable to misuse because cards can be transferred between users, allowing proxy attendance to occur [2], [3]. Therefore, integrating biometric authentication such as fingerprint sensors is recommended due to their unique physiological characteristics that are difficult to forge and provide higher identification accuracy [2].

In addition to authentication improvements, IoT-based attendance systems also enable real-time data logging, cloud storage integration, and automated communication with related stakeholders [3]. The combination of RFID and fingerprint authentication has been shown to enhance the security and reliability of attendance systems through dual-factor authentication mechanisms [4], [5]. Such integration ensures that attendance records are linked directly to the actual user identity, thereby minimizing fraud and improving system integrity. Furthermore, IoT technology enables centralized monitoring of attendance data through cloud-based platforms, making it easier for institutions to manage attendance records efficiently and transparently [8].

Despite these technological advancements, the use of biometric data such as fingerprints raises concerns regarding data security and privacy. Biometric information is categorized as sensitive personal data because it is unique to each individual and cannot be replaced once compromised. Therefore, appropriate protection mechanisms must be implemented to ensure secure handling of biometric data in digital systems [3]. In this study, the proposed system does not store raw fingerprint images in the database. Instead, the fingerprint sensor stores biometric templates locally within the sensor module, while the system only transmits identification data and attendance timestamps to the cloud database. This approach helps minimize privacy risks while maintaining the functionality and reliability of the IoT-based attendance system.

Nevertheless, most existing attendance systems primarily focus on recording presence without providing contextual information regarding student attendance status. For example, systems often record whether a student is present or absent but do not classify whether the student arrived on time, left

early, or requested permission to leave. This limitation reduces the effectiveness of attendance monitoring and student supervision. Consequently, this research develops an IoT-based attendance system integrating RFID, fingerprint sensors, attendance status buttons (arrive, depart, and leave), and parental notifications to improve data accuracy and student monitoring capabilities [5]–[7].

Various studies have attempted to replace conventional attendance systems with digital solutions. For instance, IoT-based attendance systems using RFID technology have been developed to automate attendance recording and reduce manual errors, demonstrating improved reliability and real-time data management [12]. Other studies highlight that RFID-based attendance systems integrated with cloud services enable centralized monitoring and faster data processing in educational environments [13]. In addition, multi-modal attendance systems integrating RFID with communication platforms such as WhatsApp have been proposed to enhance monitoring by sending automatic notifications to relevant stakeholders [14]. The integration of biometric technologies such as fingerprint sensors has also been explored to strengthen authentication mechanisms and prevent proxy attendance [15]. Furthermore, several studies have implemented dual authentication mechanisms combining RFID and fingerprint recognition in IoT-based systems to improve system security and identity verification accuracy [16]. These studies demonstrate that IoT-based attendance systems significantly improve automation, monitoring capabilities, and authentication reliability compared to traditional attendance methods.

In addition, several recent studies have further explored the application of IoT technology in educational attendance monitoring systems. IoT-based architectures allow attendance devices to communicate with cloud platforms, enabling real-time data synchronization, remote monitoring, and automated reporting. Such systems improve administrative efficiency by reducing manual data processing and enabling centralized data management. Moreover, IoT technology supports the integration of multiple identification mechanisms, including RFID cards, biometric sensors, and mobile-based authentication, which enhances both flexibility and system reliability. Previous studies also indicate that IoT-enabled attendance systems can significantly improve transparency in attendance monitoring and facilitate communication between schools and parents through digital notification services and online monitoring platforms [8], [9], [10].

Although previous research has demonstrated the effectiveness of RFID, biometric authentication, and IoT technologies in attendance management, most studies still focus primarily on recording attendance data without integrating automated attendance classification and real-time parental notification mechanisms. Additionally, limited research has explored the use of decision-based systems to automatically determine attendance status based on predefined rules. In educational environments, such automation is important to support objective monitoring of

student discipline and improve communication between schools and parents. Previous studies have also emphasized the importance of transparent information systems that facilitate communication between schools and parents in monitoring student activities and academic progress [11].

Based on the identified limitations of conventional attendance systems and previous digital attendance studies, this research proposes an IoT-based attendance system that integrates RFID and fingerprint dual authentication to improve identity verification and prevent proxy attendance. In addition, the system incorporates a Rule-Based Decision System (RBDS) to automatically classify student attendance status based on real-time attendance data, enabling more objective monitoring of attendance discipline. Another contribution of this study is the integration of real-time parental notifications via WhatsApp, allowing parents to receive immediate information regarding their children's attendance. Furthermore, the proposed system presents an integrated IoT architecture combining ESP32, biometric authentication, cloud-based data storage, and automated communication services, enabling more transparent and efficient attendance monitoring in educational environments.

The proposed system not only records attendance but also supports automated attendance classification and parental notification, which distinguishes it from many existing IoT-based attendance systems.

II. METHOD

This study employs a sequential dual-factor authentication method (Two-Factor Authentication/2FA) combining RFID identification and fingerprint biometric verification to enhance security and prevent attendance fraud, as well as a Rule-Based Decision System (RBDS) for more rigorous and objective classification of attendance and lateness [11]. The Rule-Based Decision System (RBDS) used in this study is designed with configurable rule parameters that allow flexible adjustment of attendance classification criteria. For example, the threshold defining on-time attendance or late arrival can be modified according to changes in school policies, such as adjustments to the official start time of classes. This flexibility enables the system to adapt to different institutional regulations without requiring modifications to the core system architecture. The approach used is software engineering with a prototype development model and experimental design aimed at improving student attendance discipline at SMK Tri Tunggal 45 Makassar as the site of implementation and testing.

In the proposed system, RFID and fingerprint authentication are not used as alternative methods but as sequential dual-factor authentication mechanisms. The attendance process begins when a student taps their RFID card to identify the registered card UID. After the RFID card is verified, the student must perform fingerprint scanning for biometric verification. The ESP32 microcontroller then compares both the RFID UID and the fingerprint ID with the registered student identity stored in the database. The

attendance process is only accepted when both authentication factors match the same student identity. This sequential verification mechanism ensures higher reliability and prevents proxy attendance.

The experiment involved 25 students and was conducted over a four-week period. The first week (19–23 January 2026) was used to observe the conventional manual attendance system as a baseline for comparison. Subsequently, the IoT-based attendance system integrating RFID and fingerprint authentication was implemented for three consecutive weeks (26–30 January 2026, 2–6 February 2026, and 9–13 February 2026). The attendance data collected from both systems were analyzed to evaluate improvements in attendance monitoring and student attendance discipline.

After tapping the RFID card and scanning their fingerprint, students select a menu button corresponding to their attendance status. This feature serves as an active verification mechanism, ensuring that attendance records reflect the attendance condition rather than only the timestamp. All attendance data are automatically transmitted via the internet to a cloud database (Google Sheets) and integrated with a real-time notification system that sends attendance updates to parents. The system is installed at the main entrance gate of SMK Tri Tunggal 45 Makassar to ensure that every student completes the attendance process before entering the school environment.

A. Circuit Block Diagram

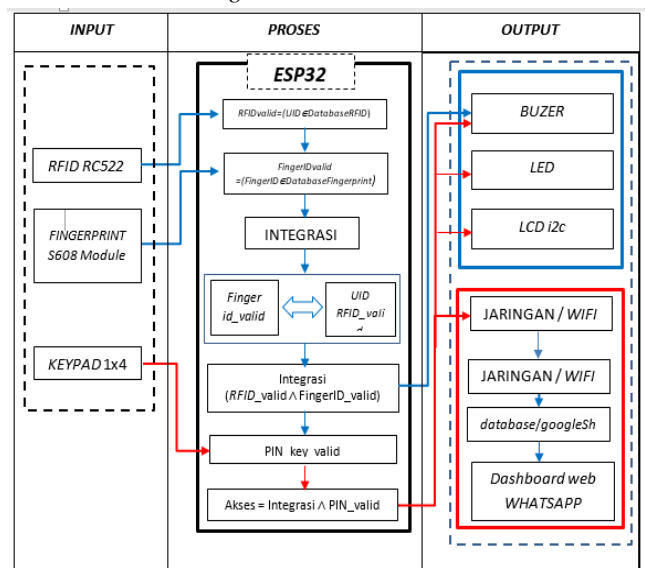

Fig. 1. Block Diagram

The process begins when students authenticate using the S608 fingerprint sensor and an RFID card. Data from both sensors are verified by the ESP32, after which students select their attendance type through a keypad. If the verification is successful, the system displays attendance information on the LCD as feedback, accompanied by buzzer and LED indicators. The attendance data are then automatically stored

in a cloud database via Google Sheets provided by Google, and the system sends real-time notifications to parents or administrators through WhatsApp. This process ensures that attendance recording is fast, accurate, and integrated.

B. System Architecture

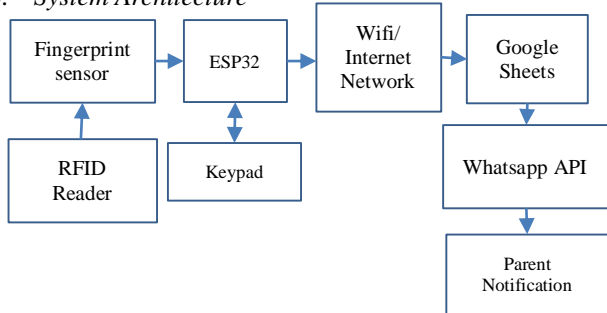

Fig. 2. System Architecture

The figure illustrates the architecture of the proposed IoT-based attendance system with dual verification using RFID and fingerprint technologies. During the attendance process, students first tap their RFID card and scan their fingerprint for identity verification. After successful authentication, students select their attendance status using the keypad. The authentication data and selected status are then processed by the ESP32 microcontroller and transmitted via WiFi to the cloud server, where the attendance records are stored in Google Sheets for real-time monitoring. The system also sends automatic attendance notifications to parents via WhatsApp. To maintain data privacy, only student identification numbers and attendance timestamps are transmitted to the cloud, while biometric fingerprint templates remain stored locally in the fingerprint module and are not transmitted over the network.

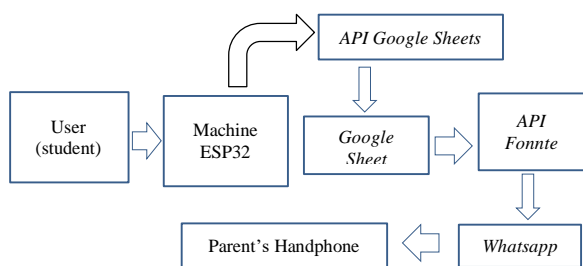

Fig. 3. Notification Delivery Process Flow

Figure 3 Show the notification process begins when a student performs attendance authentication using RFID or a fingerprint sensor. The system then verifies the student's identity and records the attendance data, which are transmitted and stored in the cloud database (Google Sheets). After the data are stored, the system retrieves the parent's WhatsApp number from the database. The server subsequently sends a request to the Fonnte WhatsApp API to generate a notification message. The Fonnte service processes

the request and forwards the message to the parent's WhatsApp account, allowing parents to receive real-time notifications regarding their child's attendance status.

C. Fingerprint and RFID Electronic Circuit.

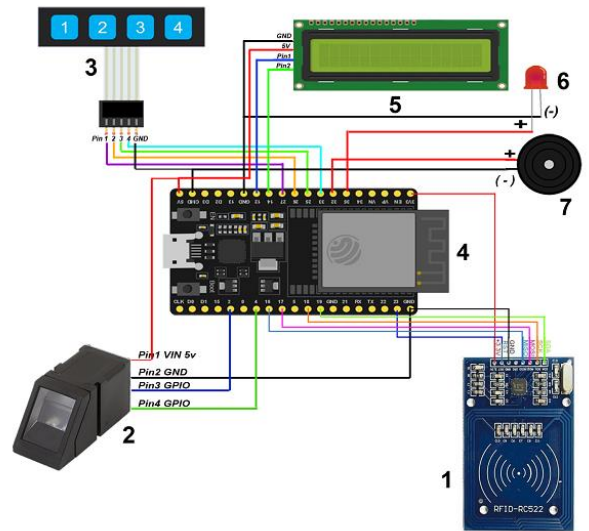

Fig. 4. Fingerprint and RFID Circuit Schematic

- 1) *RFID RC522.* An RFID reader module is used to read RFID cards or tags as an additional identification method.
- 2) *Fingerprint Sensor S608 Modul.* It is used to scan and recognize students' fingerprints as a biometric identification method.
- 3) *Keypad 1x4.* It is used to input attendance status selections such as present, departure, permission, or sick.
- 4) *ESP32.* The main microcontroller that processes data from all sensors and transmits it to the server or cloud.
- 5) *LCD I2C.* Displays attendance status information, scan results, or system messages.
- 6) *LED.* Serves as a visual indicator, for example by signaling successful or failed attendance recording.
- 7) *Spekaer Buzzer.* Provides an audio notification to indicate the result of the attendance process or any errors.

TABLE I
ESP32 CONNECTION WIRING PATH

| No | compo nent | Number of Pin compon ent | Pin ESP 32 | Color of cable | Function |
|----|---------------------|--------------------------|------------|----------------|--------------------|
| 1 | Finger print Sensor | PIN1 VCC 3V | 3V | red | Supply tegangan 3V |
| | | PIN2 GND | GN D | black | Ground Fingerprint |
| | | PIN2 GPIO | Pin 32 | blue | TX / RX komunikasi |

| | | | | | |
|---|----------------|-----------|---------------|---------|--------------------------|
| 2 | RFID RC522 | PIN3 GPIO | Pin 33 | green | RX / TX komunikasi |
| | | 3V | 3V | red | Supply tegangan 3v |
| | | GND | GN D | black | Ground RFID |
| | | SDA | Pin 19 | gren | Pin SS (Slave Select) |
| | | SCK | Pin 18 | red | Clock SPI |
| | | MOSI | Pin 17 | Pink | Data Master Out |
| | | MISO | Pin 16 | blue | Data Master In |
| 3 | Keypad 1x4 | Rst | Pin 23 | Orang e | Reset |
| | | PIN1 GPIO | Pin 27 | purple | Keypad Pin1 (Tombol "1") |
| | | PIN2 GPIO | Pin 26 | Orang e | Keypad Pin2 (Tombol "2") |
| | | PIN3 GPIO | Pin 25 | green | Keypad Pin3 (Tombol "3") |
| | | PIN4 GPIO | Pin 14 | blue | Keypad Pin4 (Tombol "4") |
| 4 | LCD 16x2 (I2C) | GND | GN D | black | Ground Keypad |
| | | VCC 5V | 5V | red | VCC LCD Sumber daya LCD |
| | | PIN1 GPIO | Pin 16 (SD A) | green | Data I2C |
| | | PIN2 GPIO | Pin 17 (SC L) | blue | Clock I2C |
| 5 | Buzzer | + | Pin 4 | red | Positif buzzer |
| | | GND (-) | GN D | black | Negatif buzzer |
| 6 | LED | + | Pin 2 | red | Positif LED |
| | | GND (-) | GN D | black | Negatif LED |

D. Hardware

1) *ESP32*. A microcontroller with WiFi and Bluetooth capabilities used to control the IoT system, featuring multiple GPIO pins and a dual-core processor.

2) *S608 Fingerprint Sensor Module*. A fingerprint reader module used to match student identities based on pre-recorded fingerprint features. The fingerprint scanner has a capacity of up to 127 fingerprint records and a fast verification time (< 2 seconds).

3) *RFID RC522 Module Card Reader*. An RFID card reader module used to identify students based on the unique ID stored on RFID cards. It reads RFID cards at a frequency of 13.56 MHz with a reading distance of approximately 2–5 cm.

4) *MFRC522 RFID Reader*. An alternative RFID reader module operating at a frequency of 13.56 MHz with a reading distance of up to 5 cm.

5) *Push Button (Keypad 1x4)*. Functions as an input interface that must be pressed by students after fingerprint scanning and RFID card tapping.

6) *Jumper-Wires*. Connecting wires used to link modules or components on a breadboard, available in various connector types (male–female).

7) *Buzzer-Speaker*. Used to produce sound indicators for system processes (3–5 V).

8) *LED-Light*. Used to provide system response indicators in the form of light signals.

9) *Resistor*. Used to provide voltage resistance to the current supplied to the LED used as an indicator.

10) *LCD-I2C*. LCD I2C 16x2: A display with 2 rows × 16 characters used to present information, utilizing an I2C interface.

11) *Access-Point*. A data communication medium for the IoT system through a wireless network, using a 2.4 GHz access point.

TABLE II
HARDWARE SPECIFICATIONS OF THE PROPOSED SYSTEM

| No | Device | Model / Type | Main Specifications |
|----|--------------------|-------------------------|--|
| 1 | Microcontroller | ESP32 | Dual-core 240 MHz, WiFi 802.11 b/g/n, Bluetooth, 34 GPIO pins |
| 2 | RFID Reader | MFRC522 / RC522 | Frequency 13.56 MHz, SPI interface, reading distance 2–5 cm |
| 3 | Fingerprint Sensor | S608 Fingerprint Module | Optical fingerprint sensor, storage capacity up to 127 fingerprints, verification time < 2 seconds |
| 4 | Keypad | 1x4 Push Button | Digital input interface |
| 5 | Display | LCD 16x2 I2C | I2C communication interface |
| 6 | Buzzer | Active Buzzer | 3–5V operating voltage |
| 7 | LED Indicator | Standard LED | 2–3V operating voltage |
| 8 | Network Device | WiFi Access Point | 2.4 GHz wireless communication |

The use of biometric data in this study was conducted solely for student attendance authentication purposes. Prior to system implementation, approval was obtained from the school management, and students as well as parents were informed about the use of RFID and fingerprint authentication. The collected biometric data were used only for identity verification and were not shared with third parties. All attendance records were securely stored in the cloud database with restricted access to authorized personnel to ensure data privacy and protection.

E. Research Location

The research was conducted at SMK Tri Tunggal 45 Makassar under the auspices of Yayasan Pendidikan Al-Qahhar, located on Jl. Kemuliaan Bangkala, BTP, Makassar, South Sulawesi.

F. Software

Software yang digunakan dalam penelitian ini meliputi sistem operasi Windows, Arduino IDE, bahasa pemrograman C/C++, Google Sheets, Realtime Firebase Database, Web Dashboard berbasis App Script, WhatsApp, Draw.io, serta Google Drive.

G. Use Case Diagram of RFID and Fingerprint Attendance System.

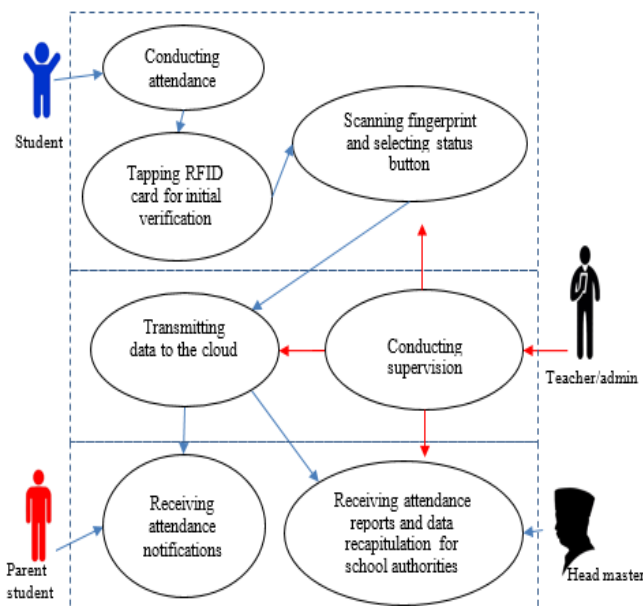

Fig. 5. Attendance Use Case Diagram

H. Flowchart System

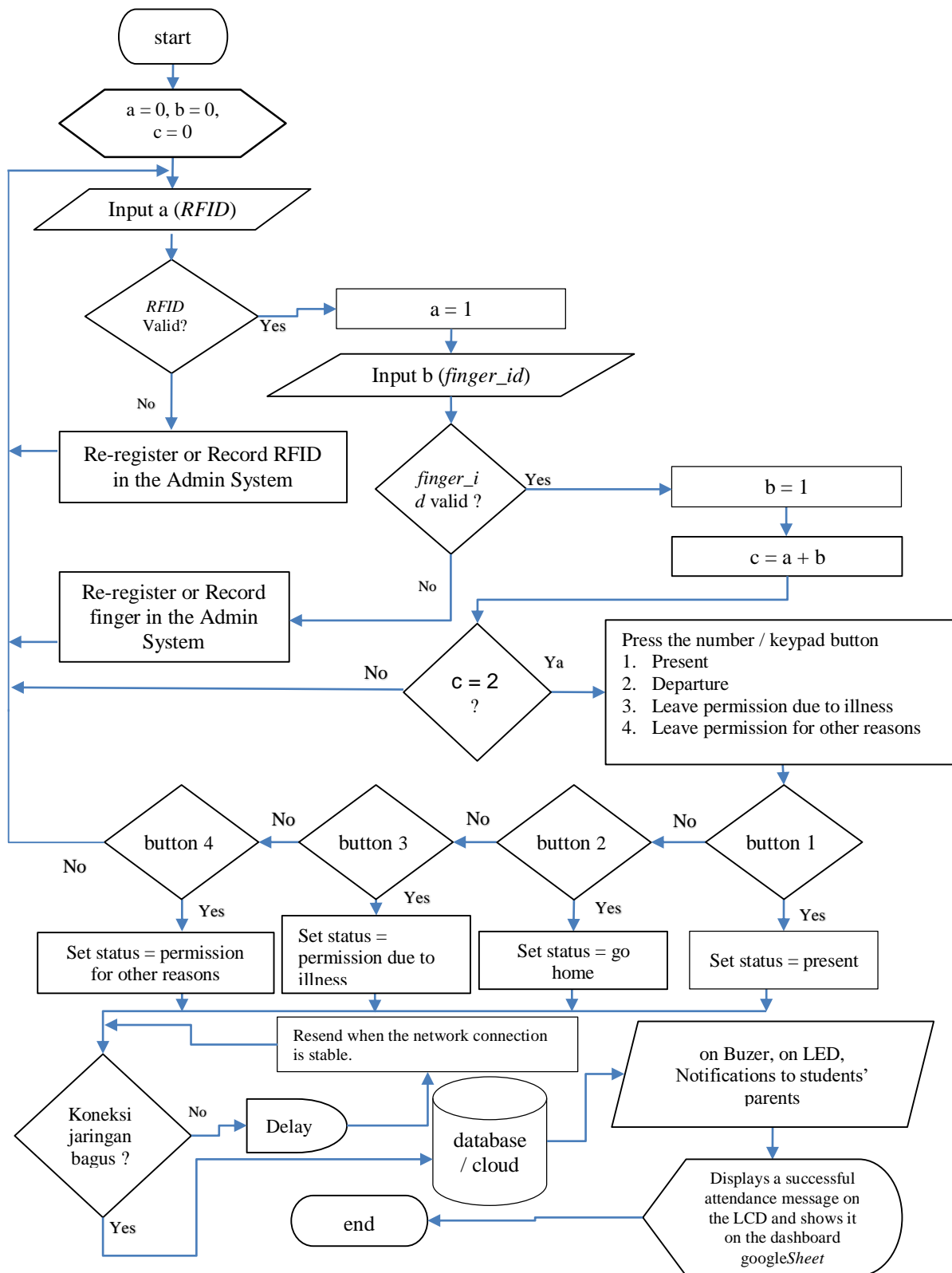

Fig. 6. Flowchart System

III. RESULT AND DISCUSSION

A. Research Results

1. Hardware Research Results

This study produced an Internet of Things (IoT)-based student attendance system that integrates fingerprint and RFID sensors as dual authentication methods to minimize fraud and improve student discipline. The system uses the ESP32 as the data processing unit, which is connected to a fingerprint sensor, RFID module, keypad, LCD, buzzer, and LED in a single integrated device. The attendance process is carried out through RFID card verification and fingerprint scanning, after which the attendance data are transmitted and stored in Google Sheets provided by Google, allowing real-time monitoring. The test results show that the system operates properly and stably, provides accurate and informative attendance records, and supports notifications to students' parents.

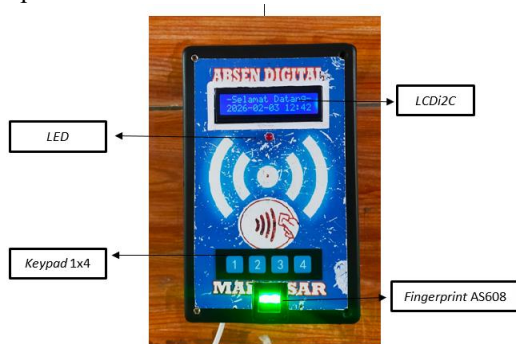

Fig. 7. IoT-based digital attendance machine (external view)

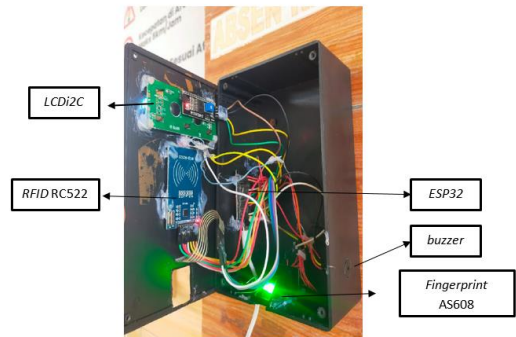

Fig. 8. IoT-based digital attendance machine (internal view)

2. Software Research Results

The software system includes identity data integration, attendance data storage, automatic notifications, and a monitoring dashboard. Firebase Realtime Database is used as a medium for integrating student identity data, such as student ID numbers (NIS), names, RFID UIDs, and fingerprint IDs, ensuring that the authentication process is performed only when both identities match and helping to minimize attendance fraud.

Attendance data are automatically stored in Google Sheets through Google Apps Script provided by Google. The stored data include student identity, time, and attendance status,

thereby facilitating monitoring and data recapitulation without requiring a dedicated server.

The system is also equipped with automatic notifications to parents sent in real time after the attendance process, thereby enhancing student attendance monitoring. In addition, the web-based monitoring dashboard provides real-time attendance data displays as well as features for student data management, manual attendance input, and attendance recapitulation to support supervision by the school.

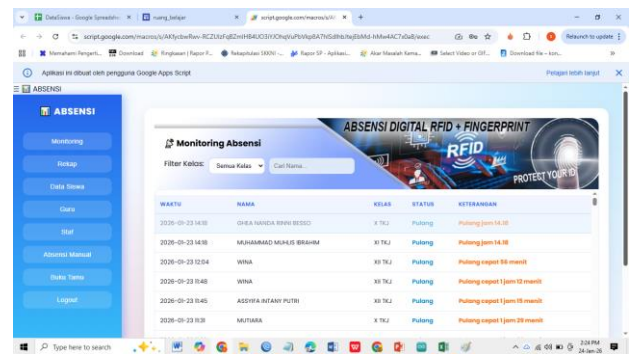

Fig. 9. Dashboard Web

B. System Analysis Testing Results

1. RFID Testing

Testing of the RFID RC522 card and RC-522 reader showed that the system is capable of reading cards quickly and stably at a distance of 0 to 3 cm, with a response time of less than 2 seconds. The testing was conducted in five trials.

TABLE III
RFID TESTING

| No | Testing Scenario | Input | Test Results | Description |
|----|--------------------------------|-----------------------|---|--------------------------------|
| 1 | Registered RFID card reading | Student RFID card | Trials 1-5: UID successfully read and transmitted | Successful (5 out of 5 trials) |
| 2 | Unregistered RFID card reading | Unknown/new RFID card | Trials 1-5: Access denied / INVALID | Successful (5 out of 5 trials) |
| 3 | Optimal reading distance | Card at ±3 cm | Trials 1-5: UID read in < 2 seconds | Successful (5 out of 5 trials) |
| 4 | Excessive reading distance | Card >4 cm | Trials 1-5: UID not detected | Successful (5 out of 5 trials) |

Based on the testing results, the RFID sensor is able to read registered cards properly and reject unregistered cards. The optimal reading distance ranges from approximately 0 to 3 cm.

2. Fingerprint Sensor Testing

Testing of the fingerprint sensor showed that the sensor is able to recognize registered fingerprints and reject unregistered ones with a fast identification process and high

accuracy. However, the accuracy decreases when the finger is wet, dirty, or improperly positioned. These results indicate that the sensor is suitable for use as a biometric authentication method in the attendance system.

TABLE IV
FINGERPRINT SENSOR TESTING

| No | Testing Scenario | Input | Test Results | Description |
|----|--------------------------|------------------------------------|--|---------------------------------|
| 1 | Registered fingerprint | Registered student finger | Trials 1-5: Fingerprint ID recognized | Successful (5 out of 5 trials) |
| 2 | Unregistered fingerprint | Unregistered student finger | Trials 1-5: System rejects attendance | Successful (5 out of 5 trials) |
| 3 | Proper finger position | Normal finger | Trials 1-5: Response time ±1 second | Successful (5 out of 5 trials) |
| 4 | Improper finger position | Finger not aligned with the sensor | Trials 1-5: Response time ±4 seconds, system rejects | Successful (5 out of 5 trials) |
| 5 | Wet/dirty finger | Non-ideal finger condition | Trials 1-5: All attempts failed | As expected (5 out of 5 trials) |

Fingerprint sensor testing was conducted to determine the sensor’s capability in recognizing students’ fingerprints. Based on the test results, the sensor was able to recognize registered fingerprints and reject unregistered fingerprints.

3. Keypad 1x4 Button Testing

Keypad button testing was conducted by involving students who had successfully validated their UID and fingerprint ID in the system, with a total of five trials.

TABLE V
KEYPAD 1X4 BUTTON TESTING

| No | Testing Scenario | User Action | Test Results | Description |
|----|------------------------------------|--------------------------------|---|--------------------------------|
| 1 | Button 1 “Present” | Pressing the Present button | “Present” status data transmitted to the system | Successful (5 out of 5 trials) |
| 2 | Button 2 “Departure” | Pressing the Departure button | “Departure” status data transmitted to the system | Successful (5 out of 5 trials) |
| 3 | Button 3 “Leave Permission – Sick” | Pressing the Sick Leave button | “Sick Leave” status data transmitted | Successful (5 out of 5 trials) |

| No | Testing Scenario | User Action | Test Results | Description |
|----|---|---------------------------------------|--|--------------------------------|
| 4 | Button 4 “Leave Permission – Other Reasons” | Pressing the Leave Reason button | “Leave Permission – Other Reasons” status data transmitted to the system | Successful (5 out of 5 trials) |
| 5 | No button selected | No further attendance process appears | System fails attendance and returns to the initial state | Successful (5 out of 5 trials) |

The test results show that, in five trials, each of the five keypad buttons was able to distinguish the type of attendance status according to the number of the pressed button with a high success rate, with an average response time of approximately 1 second.

4. Testing of the RFID Card and Fingerprint Sensor Integration Process on ESP32.

Testing was conducted in five trials to evaluate the system for matching UID and fingerprint ID (id_finger) data between Firebase and the ESP32.

TABLE VI
TESTING OF THE RFID CARD AND FINGERPRINT SENSOR INTEGRATION PROCESS ON ESP32

| UID | Finger_ID | Classes | Name | Number of Trials | Validation Result |
|----------|-----------|---------|------------------------|------------------|------------------------------|
| 712D C96 | 41 | X TKJ | ADELI A | 5 trials | 100% success from trials 1-5 |
| A9F7 C96 | 31 | X TKJ | MUTIA RA | 5 trials | 100% success from trials 1-5 |
| 6C4C CA6 | 26 | X TKJ | BERTO LOME US N VISKI | 5 trials | 100% success from trials 1-5 |
| CC66 C96 | 30 | X TKJ | MUH REZKY SETIA WAN | 5 trials | 100% success from trials 1-5 |
| C742 CB6 | 28 | X TKJ | GHEA NANDA RINNI BESSO | 5 trials | 100% success from trials 1-5 |

From five trials for each card and fingerprint, the test results show that the ESP32 successfully matched the UID and fingerprint ID according to the stored data, resulting in a validation rate of 100%. This demonstrates that the initial authentication process on the device side operates properly and is capable of ensuring that the card and fingerprint

identities belong to the same student before the attendance process proceeds.

5. Database and Notification Testing

Testing was conducted on the system for transmitting student attendance data after the attendance process was completed. The results from five trials show that the student attendance data were successfully sent to the database, and notifications were also delivered to students' parents or guardians through WhatsApp.

TABLE VII
DATABASE AND NOTIFICATION TESTING

| No | Module/Action | Testing Scenario | Test Results | Status |
|----|-------------------|--|---|-------------------------|
| 1 | Authentication | RFID + Finger match + button pressed | Data recorded in Google Sheets provided by Google | Valid (from trials 1-5) |
| 2 | Authentication | RFID ≠ Finger | Attendance rejected | Valid (from trials 1-5) |
| 3 | Attendance Status | Select "Present" | Status stored | Valid (from trials 1-5) |
| 4 | Attendance Status | Select "Sick Leave" | Status stored | Valid (from trials 1-5) |
| 5 | Database | Send to Google Sheets provided by Google | Data stored | Valid (from trials 1-5) |
| 6 | Notification | Attendance successful | Message sent via WhatsApp | Valid (from trials 1-5) |

Based on the testing results, all main system functions operated according to the designed scenarios. Dual authentication using RFID and fingerprint was able to accurately validate student identities. In addition, integration with Google Sheets provided by Google and the WhatsApp notification system demonstrated successful real-time data transmission and storage.

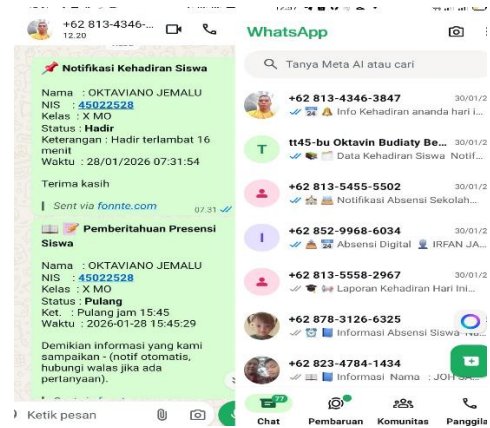

Fig. 10. Student attendance notification via WhatsApp

6. Testing of the Rule-Based Decision System (RBDS) Method.

Rule-Based Decision System testing was conducted to determine students' attendance status based on predefined time rules. The system applies specific time tolerance limits relative to the school's entry time to classify student attendance into early arrival, on-time attendance, and late attendance.

The attendance status classification in this study is determined using a Rule-Based Decision System (RBDS) that evaluates the difference between the student's arrival time and the official school entry time. The RBDS operates using a set of predefined logical rules that classify attendance based on a tolerance interval. The decision variable x represents the difference between the arrival time and the scheduled entry time, expressed in minutes. The classification rules are defined as follows:

$$x = T_{arrival} - T_{entry}$$

where:

- a. $T_{arrival}$ = student arrival time
- b. T_{entry} = official school entry time
- c. x = time difference in minutes.

Based on this value, the attendance status is determined using the following rule set :

$$status \begin{cases} Early & \text{if } x < -15 \\ OnTime & \text{if } -15 \leq x \leq 15 \\ Late & \text{if } x > 15 \end{cases}$$

These rules allow the system to automatically determine student attendance status based on the predefined tolerance limits.

TABLE VIII
ATTENDANCE TOLERANCE

| No | Arrival Time Difference (minutes) | Time Condition | Rule | Attendance Status |
|----|-----------------------------------|------------------------------------|--|--------------------|
| 1 | $x < -15$ | Arrives well before entry time | If arrival is earlier than the tolerance limit | Early arrival |
| 2 | $-15 \leq x \leq +15$ | Arrives within the tolerance range | If arrival is within the tolerance limit | On-time attendance |
| 3 | $x > +15$ | Arrives beyond the tolerance limit | If arrival exceeds the tolerance limit | Late attendance |

$$\text{Attendance Percentage} = \frac{\text{Number of Present Students}}{25 \text{ Students}} \times 100\%$$

Rule-Based Decision System Calculation

Sample Testing Case:

A student performs attendance at 07:30, with the school entry time at 07:20.

1. Time conversion to minutes
 - a. Entry time = $7 \times 60 + 20 = 440$ minutes
 - b. Arrival time = $7 \times 60 + 30 = 450$ minutes
2. Calculate the time difference
 $X = 450 - 440 = +10$ minutes
3. Rule evaluation
Based on the rule base table:
 $X = 10$ falls within the range $-15 \leq x \leq +15$
4. System Decision = On-Time Attendance

C. Student Attendance Data Analysis

1. Analysis of Student Attendance Data Based on the Internet of Things (IoT).

The analysis was conducted by comparing attendance data before and after the implementation of the IoT-based system. The previous system only recorded attendance in a simple manner, whereas the IoT system automatically records time and attendance status in real time. The results show an increase in on-time attendance, a decrease in lateness, and more organized recording of student leave, thereby having a positive impact on attendance discipline.

2. Comparison of Student Attendance Data Before and After System Implementation

The experimental testing was conducted over a three-week period, covering Week IV of January 2026 (January 26–30, 2026), Week I of February 2026 (February 2–6, 2026), and

Week II of February 2026 (February 9–13, 2026) for Class X TKJ. Student attendance data were collected from both manual attendance records and the IoT-based attendance system. The total number of students involved in the experiment was 25 students. The percentage was calculated using :

TABLE IX
STUDENT ATTENDANCE RECAPITULATION (MANUAL ATTENDANCE) FOR JANUARY 19–23, 2026

| Day/Date | Attendance Status | | | Present | Absent | Percentage |
|-----------------------|-------------------|--------------------|-----------------|---------|--------|------------|
| | Early Arrival | On-Time Attendance | Late Attendance | | | |
| Monday, 19-01-2026 | 0 | 0 | 0 | 14 | 11 | 56% |
| Tuesday, 20-01-2026 | 0 | 0 | 0 | 19 | 6 | 76% |
| Wednesday, 21-01-2026 | 0 | 0 | 0 | 18 | 7 | 72% |
| Thursday, 22-01-2026 | 0 | 0 | 0 | 20 | 5 | 80% |
| Friday, 23-01-2026 | 0 | 0 | 0 | 19 | 6 | 76% |
| Average | | | | | | 72% |

Based on Table IX of the attendance data for Class X TKJ students, the manual attendance system shows an average attendance rate of 72%. This system only records presence and absence without considering punctuality, thus providing less detailed insight into student discipline.

TABLE X
STUDENT ATTENDANCE RECAPITULATION (IOT-BASED DIGITAL ATTENDANCE) FOR JANUARY 26–30, 2026

| Day/Date | Attendance Status | | | Present | Absent | Percentage |
|-----------------------|-------------------|--------------------|-----------------|---------|--------|------------|
| | Early Arrival | On-Time Attendance | Late Attendance | | | |
| Monday, 26-01-2026 | 0 | 14 | 1 | 15 | 10 | 60% |
| Tuesday, 27-01-2026 | 5 | 10 | 4 | 19 | 6 | 76% |
| Wednesday, 28-01-2026 | 6 | 9 | 3 | 18 | 7 | 72% |
| Thursday, 29-01-2026 | 5 | 15 | 1 | 21 | 4 | 84% |
| Friday, 30-01-2026 | 3 | 12 | 5 | 19 | 6 | 76% |
| Average | | | | | | 74% |

Based on Table X of the attendance data for Class X TKJ students, the implementation of the IoT-based attendance system in the first week showed an increase in the average attendance rate to 74%. In addition to recording presence and absence, this system also records attendance time in detail.

TABLE XI
STUDENT ATTENDANCE RECAPITULATION (IOT-BASED DIGITAL ATTENDANCE) FOR FEBRUARY 2-6, 2026

| Day/Date | Attendance Status | | | Present | Absent | Percentage |
|-----------------------|-------------------|--------------------|-----------------|---------|--------|------------|
| | Early Arrival | On-Time Attendance | Late Attendance | | | |
| Monday, 02-02-2026 | 9 | 11 | 2 | 22 | 3 | 88% |
| Tuesday, 03-02-2026 | 8 | 9 | 4 | 21 | 4 | 84% |
| Wednesday, 04-02-2026 | 7 | 15 | 2 | 24 | 1 | 96% |
| Thursday, 05-02-2026 | 6 | 7 | 1 | 14 | 11 | 56% |
| Friday, 06-02-2026 | 10 | 11 | 1 | 22 | 3 | 88% |
| Average | | | | | | 82% |

Based on the Table XI, the attendance data of Class X TKJ students show that the implementation of the IoT-based attendance system in the second week resulted in a further increase in the average attendance rate to 82%.

TABLE XII
STUDENT ATTENDANCE RECAPITULATION (IOT-BASED DIGITAL ATTENDANCE) FOR FEBRUARY 9-13, 2026

| Day/Date | Attendance Status | | | Present | Absent | Percentage |
|-----------------------|-------------------|--------------------|-----------------|---------|--------|------------|
| | Early Arrival | On-Time Attendance | Late Attendance | | | |
| Monday, 09-02-2026 | 5 | 16 | 2 | 23 | 2 | 92% |
| Tuesday, 10-02-2026 | 9 | 14 | 0 | 23 | 2 | 92% |
| Wednesday, 11-02-2026 | 5 | 13 | 2 | 20 | 5 | 80% |
| Thursday, 12-02-2026 | 4 | 17 | 1 | 22 | 3 | 88% |
| Friday, 13-02-2026 | 4 | 15 | 2 | 21 | 4 | 84% |
| Average | | | | | | 87% |

Following the implementation of the IoT-based digital attendance system and its comparison with manual records, the average student attendance rate showed a consistent upward trend. While the manual attendance stood at 72%, it increased to 74% in the first week of IoT implementation, rose significantly to 82% in the second week, and further reached 87% in the subsequent week. Overall, this represents an improvement of approximately 15 percentage points compared to the manual attendance method. In addition to improving attendance percentages, the IoT system is capable

of classifying arrival times into early, on-time, and late categories, resulting in more accurate and informative data.

The testing results indicate that the Internet of Things (IoT)-based attendance system is capable of recording attendance automatically and in real-time. The system effectively identifies late arrivals and neatly organizes records for students leaving early due to illness or other personal matters. These features significantly contribute to enhancing student discipline compared to the conventional manual attendance system.

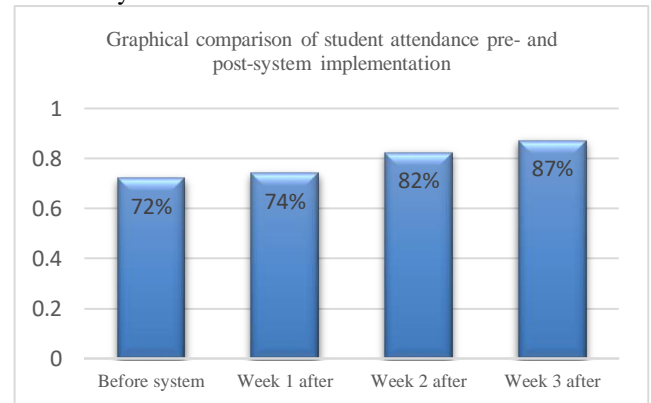

Fig. 11. Graphical comparison of student attendance pre- and post-system implementation.

Figure 11 presents a comparison of student attendance before and after the implementation of the IoT-based attendance system. The quantitative results indicate a significant improvement in student attendance discipline following the adoption of the proposed system. The average attendance rate increased from 72% in the manual system to 87% after three weeks of IoT-based implementation, representing an improvement of approximately 15 percentage points. Furthermore, student tardiness, which was previously not recorded in the manual system, became measurable after the system implementation and showed a consistent decline from 15% in the first week, to 10% in the second week, and further to 7% in the third week. These findings demonstrate that the IoT-based attendance system improves both the accuracy of attendance monitoring and student punctuality.

D. Analysis of Student Tardiness Data.

The measurement of student tardiness as an indicator of discipline was conducted by comparing attendance latency data before and after the implementation of the IoT-based attendance system.

TABLE XIII
TARDINESS DATA FOR FEBRUARY 19-23, 2026 (MANUAL RECORDS: PRE-SYSTEM IMPLEMENTATION)

| Day/Date | Attendance Status | | | Present (On Time) | Present (Late) | Percentage (%) |
|---------------------|-------------------|---------|------|-------------------|----------------|----------------|
| | Early | On Time | Late | | | |
| Monday, 19-01-2026 | 0 | 0 | 0 | 0 | 0 | 0 |
| Tuesday, 20-01-2026 | 0 | 0 | 0 | 0 | 0 | 0 |

| | | | | | | |
|-----------------------|---|---|---|---|---|---|
| Wednesday, 21-01-2026 | 0 | 0 | 0 | 0 | 0 | 0 |
| Thursday, 22-01-2026 | 0 | 0 | 0 | 0 | 0 | 0 |
| Friday, 23-01-2026 | 0 | 0 | 0 | 0 | 0 | 0 |
| Average | | | | | | 0 |

Based on the table XIII shows a value of zero in every attendance category. This indicates that no attendance data was recorded during this period under the manual system; consequently, the attendance percentage and the overall student attendance average cannot be calculated.

TABLE XIV
TARDINESS DATA: JANUARY 26–30, 2026 (POST-IOT DIGITAL ATTENDANCE SYSTEM – WEEK 1)

| Day/Date | Attendance Status | | | Present (On Time) | Present (Late) | Percentage (%) |
|-----------------------|-------------------|---------|------|-------------------|----------------|----------------|
| | Early | On Time | Late | | | |
| Monday, 26-01-2026 | 12 | 2 | 1 | 14 | 1 | 7% |
| Tuesday, 27-01-2026 | 8 | 7 | 4 | 15 | 4 | 21% |
| Wednesday, 28-01-2026 | 6 | 9 | 3 | 15 | 3 | 17% |
| Thursday, 29-01-2026 | 9 | 11 | 1 | 20 | 1 | 5% |
| Friday, 30-01-2026 | 9 | 6 | 5 | 15 | 5 | 25% |
| Average | | | | | | 15% |

TABLE XV
TARDINESS DATA: FEBRUARY 2–6, 2026 (POST-IOT DIGITAL ATTENDANCE SYSTEM – WEEK 2)

| Day/Date | Attendance Status | | | Present (On Time) | Present (Late) | Percentage (%) |
|-----------------------|-------------------|---------|------|-------------------|----------------|----------------|
| | Early | On Time | Late | | | |
| Monday, 02-02-2026 | 9 | 11 | 2 | 20 | 2 | 9% |
| Tuesday, 03-02-2026 | 8 | 9 | 4 | 17 | 4 | 19% |
| Wednesday, 04-02-2026 | 7 | 15 | 2 | 22 | 2 | 8% |
| Thursday, 05-02-2026 | 6 | 7 | 1 | 13 | 1 | 7% |
| Friday, 06-02-2026 | 10 | 11 | 1 | 21 | 1 | 5% |
| Average | | | | | | 10% |

Based on the table above, student attendance data for the periods of January 26–30, 2026, and February 2–6, 2026, indicates that the tardiness rate decreased from 15% to 10%.

TABLE XVI
TARDINESS DATA: FEBRUARY 9–13, 2026 (POST-IOT DIGITAL ATTENDANCE SYSTEM – WEEK 3)

| Day/Date | Attendance Status | | | Present (On Time) | Present (Late) | Percentage (%) |
|-----------------------|-------------------|---------|------|-------------------|----------------|----------------|
| | Early | On Time | Late | | | |
| Monday, 09-02-2026 | 5 | 16 | 2 | 21 | 2 | 9% |
| Tuesday, 10-02-2026 | 9 | 14 | 0 | 23 | 0 | 0% |
| Wednesday, 11-02-2026 | 5 | 13 | 2 | 18 | 2 | 10% |
| Thursday, 12-02-2026 | 4 | 17 | 1 | 21 | 1 | 5% |
| Friday, 13-02-2026 | 4 | 15 | 2 | 19 | 2 | 10% |
| Average | | | | | | 7% |

Based on Table XVI, student attendance from February 9–13, 2026, shows a further positive improvement, marked by a decrease in average tardiness to 7%, thereby reflecting enhanced student punctuality and discipline.

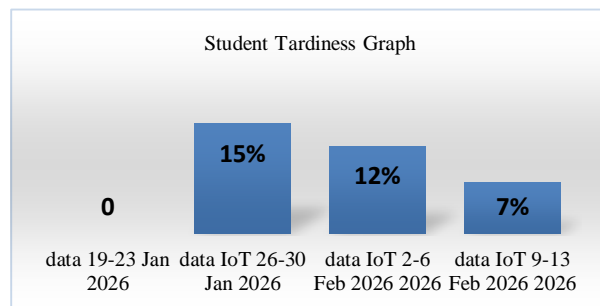

Fig. 12. Student Tardiness Graph

Based on the tardiness graph, a decline occurred following the implementation of the IoT attendance system from 0 data (January 19–23, 2026), dropping from 15% (January 26–30, 2026) to 10% (February 2–6, 2026) and further to 7% (February 9–13, 2026). This downward trend demonstrates that the system contributed to a gradual improvement in student punctuality.

The evaluation of student discipline in this study is based on descriptive trend analysis of attendance and tardiness data during the experimental period. Due to the limited sample size and short observation period, inferential statistical testing was not performed. However, the observed trends consistently indicate improvements in student attendance and punctuality after the implementation of the proposed IoT-based attendance system.

E. Manual Vs Iot-Based Attendance System Comparison.

To further clarify the advantages of the proposed system, a comparison between the conventional manual attendance method and the IoT-based attendance system is presented in Table XVII. The comparison highlights improvements in authentication reliability, data accuracy, monitoring

capability, and operational efficiency achieved through system automation.

TABLE XVII
MANUAL VS IOT-BASED ATTENDANCE SYSTEM COMPARISON

| Aspect | Manual Attendance | Proposed IoT-Based System |
|-----------------------|-----------------------|-----------------------------|
| Authentication Method | Manual signature | RFID + Fingerprint |
| Identity Validation | Not verified | Dual authentication |
| Attendance Recording | Paper-based | Automatic digital recording |
| Data Processing Time | Slow | Real-time processing |
| Data Accuracy | Prone to manipulation | High accuracy |
| Monitoring | Teacher-only | Real-time monitoring |
| Parental Notification | Not available | WhatsApp notification |
| Data Storage | Physical archive | Cloud database |
| Reporting | Manual recap | Automatic reporting |

F. System Processing Time Test

To evaluate the performance of the proposed attendance system, a delay test was conducted by measuring the processing time of each stage of the attendance procedure. The evaluated stages include RFID card detection, fingerprint verification, ESP32 data processing with Firebase integration, and data transmission to the server. Each stage was tested five times to obtain the average processing time.

TABLE XVIII
SYSTEM PROCESSING TIME TEST

| Process Stage | Average Time (s) |
|-----------------------------|------------------|
| RFID Card Detection | 1.16 |
| Fingerprint Verification | 2.1 |
| ESP32 Data Processing | 2.59 |
| Data Transmission to Server | 10.24 |
| System Reset | 1.2 |
| Total Average Time | 17.3 |

Based on the experimental results, the average total processing time for one attendance transaction is approximately 17.30 seconds per student. The longest delay occurs during data transmission to the server due to internet network latency between the ESP32 and the Firebase database. Meanwhile, RFID card detection and fingerprint verification remain relatively stable, each requiring less than three seconds.

Based on this result, the estimated time required for a class consisting of 25 students is approximately 432.5 seconds (around 7.2 minutes). This duration remains acceptable within the school attendance period and does not create significant queues, indicating that the proposed system can handle practical classroom attendance scenarios.

G. Discussion of Research Results.

1. System Authentication Performance

The research results demonstrate that integrating RFID and fingerprint sensors within an IoT-based attendance system provides reliable dual-factor authentication and contributes to improved student discipline. The system utilizes an ESP32 microcontroller for data processing, synchronizes user identities through Firebase, and stores attendance records in Google Sheets to enable real-time monitoring. Furthermore, automated WhatsApp notifications sent to parents provide an additional supervision mechanism that supports student accountability.

Each test represents one authentication attempt performed by a student. To evaluate operational performance, each of the 25 students performed three authentication attempts, resulting in a total of 75 test samples.

TABLE XIX
RFID AND FINGERPRINT ACCURACY

| Device | Total Tests | Successful | Accuracy |
|-------------|-------------|------------|----------|
| RFID | 25 | 25 | 100% |
| Fingerprint | 75 | 73 | 97% |

Testing results are summarized in Table XIX. The RFID reader achieved a 100% successful card detection rate, while the fingerprint sensor achieved 97% recognition accuracy during testing.

These results indicate that the proposed system meets the expected operational performance for school attendance applications. The RFID module demonstrated stable identification performance, while the fingerprint sensor showed high reliability with only minor false rejection cases caused by improper finger placement or sensor surface conditions. No false acceptance cases were observed during testing. In biometric authentication systems, performance is commonly evaluated using False Acceptance Rate (FAR) and False Rejection Rate (FRR), indicating that the system maintains a balance between usability and security.

2. Impact on Attendance Management.

Beyond authentication accuracy, automated recording and real-time monitoring contribute to improved attendance punctuality compared to manual attendance methods. The system's main advantages include dual-factor authentication, automated real-time recording, centralized cloud-based data storage, student leave management, and parental notification features, which collectively enhance monitoring efficiency and transparency in school attendance management.

3. Operational Limitations and System Reliability

Despite these advantages, several operational limitations should be considered. The system relies on stable internet connectivity for real-time data transmission to the cloud database. When network conditions are unstable, data transmission is temporarily delayed and automatically resent once the connection is restored. Additionally, fingerprint

recognition performance may be affected by non-ideal finger conditions, such as wet, dirty, or improperly positioned fingers, potentially causing temporary recognition failures. However, the system mitigates this issue by prompting users to repeat the scanning process until successful authentication is achieved.

4. Implementation Feasibility and Future Work.

The study was also limited by the relatively short testing period and user adaptation during early system deployment. From a practical perspective, the use of low-cost hardware components makes the system feasible for broader adoption in schools with limited resources. Future research may focus on integration with academic information systems, development of mobile applications, offline operational capability, geolocation-based attendance validation, and advanced analytics for attendance behavior analysis.

IV. CONCLUSION

Based on the design, implementation, and testing of the Internet of Things (IoT)-based attendance system conducted at SMK Tri Tunggal 45 Makassar, this study aims to determine how RFID technology and fingerprint sensors are integrated into an attendance system and to evaluate the system's accuracy in recording student attendance. Every stage of the research, from component testing to comprehensive system evaluation, has generated data that serves as the foundation for the following conclusions:

First, the integration of RFID and fingerprint sensors in an IoT-based attendance system is proven to enhance student attendance discipline. The implementation of dual-factor authentication—using RFID cards for initial identification and fingerprint sensors for unique biometric verification—successfully minimizes the potential for fraudulent practices, such as "attendance proxying" or the misuse of other students' identities. Furthermore, the system automatically records attendance in real-time and sends instant notifications to parents via WhatsApp. This mechanism strengthens the supervision of student attendance and encourages students to be more disciplined in adhering to school hours.

Second, based on the results of the comprehensive system testing, the integration of RFID and fingerprint sensors for student attendance recording demonstrates an excellent level of accuracy. The system is capable of recording and storing attendance data into the Google Sheets database with a 100% accuracy rate across all testing scenarios. Any reading errors from the fingerprint sensor during component testing did not affect the final attendance data, as the system automatically rejects invalid processes and prompts for a rescanning. Consequently, the developed attendance system exhibits high reliability and precision.

ACKNOWLEDGMENT

The author would like to express his sincere gratitude to SMK Tri Tunggal 45 Makassar for providing the opportunity

and facilities to conduct this research, from the initial observation stage to the completion of the required data analysis.

REFERENCES

- [1] S. Shingane, S. Raut, G. Kadam, T. Bhagat, M. Pawar, and U. Chuke, "Smart student attendance system," *International Journal of Research and Publication Review*, vol. 6, no. 4, pp. 10894–10900, 2025, doi: 10.55248/gengpi.6.0425.16150.
- [2] P. Gaikar, S. Patil, Y. Bhoir, and K. Kapde, "Fingerprint based attendance system," *International Journal of Advanced Research in Science, Communication and Technology*, pp. 696–703, 2025, doi: 10.48175/ijarsct-24494.
- [3] H. A. Abdulghani, N. A. Nijdam, and D. Konstantas, "Analysis on security and privacy guidelines: RFID-based IoT applications," *IEEE Access*, vol. 10, pp. 131528–131554, 2022, doi: 10.1109/ACCESS.2022.3227449.
- [4] B. M., "Attendance management system based on RFID and fingerprint reader," *International Research Journal of Computer Science*, vol. 10, no. 6, pp. 389–393, 2023, doi: 10.26562/irjcs.2023.v1006.20.
- [5] D. Borkar, "IoT based attendance system using fingerprint sensor," *International Scientific Journal of Engineering and Management*, vol. 3, no. 3, pp. 1–9, 2024, doi: 10.55041/isjem01441.
- [6] S. S. B., H. G., A. Pandit, A. Rayan, A. Singha, and B. Shrestha, "IoT based biometric student access control and attendance management," *International Journal for Research in Applied Science and Engineering Technology*, vol. 12, no. 4, pp. 5730–5735, 2024, doi: 10.22214/ijraset.2024.61370.
- [7] T. Armino, Nurfiana, D. Y. Setyawan, and N. H. Sudibyo, "Sistem monitoring kehadiran mahasiswa berbasis IoT," *JIMU: Jurnal Ilmiah Multidisipliner*, vol. 2, no. 3, pp. 834–843, 2024, doi: 10.70294/jimu.v2i03.500.
- [8] A. Kitkowska, K. Broden, and L. Abdullah, "The requirements, benefits, and barriers of IoT solutions to support well-being in elementary schools," *IEEE Access*, vol. 12, pp. 144965–144981, 2024, doi: 10.1109/ACCESS.2024.3469558.
- [9] K. Zeeshan, T. Hämäläinen, and P. Neittaanmäki, "Internet of Things for sustainable smart education: An overview," *Sustainability*, vol. 14, no. 7, 2022, doi: 10.3390/su14074293.
- [10] S. Singh, "Biometric attendance system," *International Journal of Scientific Research in Engineering and Management*, vol. 8, no. 5, pp. 1–5, 2024, doi: 10.55041/ijrsrem35127.
- [11] F. Fakhri and R. Kurniawan, "Sistem informasi pelayanan orang tua menggunakan rule-based decision support system untuk meningkatkan transparansi dan komunikasi antara sekolah dengan orang tua," *Jurnal JTIK*, vol. 8, no. 4, pp. 1071–1081, 2024.
- [12] K. Ishaq and S. Bibi, "IoT based smart attendance system using RFID: A systematic literature review," *International Journal of Advanced Computer Science and Applications*, 2023.
- [13] Y. Darmi, A. S. Utama, D. Abdullah, M. Marhalim, R. Rizky, and D. A. Lima, "A multi-modal IoT-based attendance system using RFID and WhatsApp notification for smart academic and healthcare environments," *Journal of Intelligent Computing and Health Informatics*, vol. 6, no. 1, 2025.
- [14] V. Borkar, P. Vishwakarma, L. Yadav, and V. Borkar, "Smart attendance system using RFID and IoT," *International Journal of Computer Techniques*, vol. 12, no. 4, 2025.
- [15] A. R. I. Aprilia and A. F. Waluyo, "An Internet of Things (IoT)-based attendance system using RFID technology to record employee attendance," *International Journal of Engineering Business and Social Science*, vol. 3, no. 2, 2024.
- [16] R. H. Tidar, A. Madramsyah, H. A. D. Rimbawa, and T. P. Sembali, "Design and development of an IoT-based archive room security system integrating RFID and fingerprint authentication," *Jurnal Mandiri IT*, vol. 14, no. 1, 2024.